



H2O Rx



Back Pressure and Pressure Relief Valves

Improve accuracy, prevent chemical siphoning, and prevent damage to pumps and pipework

- ◆ Field adjustable from 0-150 PSIG (0 – 1030 kPa)
- ◆ Teflon Faced EPDM Diaphragm style.
- ◆ Back Pressure Valves prevent siphoning and improve accuracy by providing a consistent load to chemical metering pumps.
- ◆ Pressure Relief valve prevents damage to pumps if inadvertently over pressured.
- ◆ Optional air release / gauge port.
- ◆ Materials include:
 - Ø PVC
 - Ø CPVC (Corzan)
 - Ø PVDF
 - Ø Polypropylene
 - Ø Teflon
 - Ø Stainless Steel 316
 - Ø Alloy 20
 - Ø Hastelloy C 276
- ◆ 7 sizes from ¼" to 2"
- ◆ Colour coded handles indicate size
- ◆ Three Year FACTORY warranty! (optional)

Back Pressure & Relief

TV Series

DESCRIPTION

Back pressure and pressure relief valves can improve accuracy and safety of pumps and processes – they do this by enhancing the effectiveness of pumps, reducing maintenance costs and time, reducing wastage of chemical, and preventing damage of equipment and pipework.

These valves are diaphragm style. The range include two types - back pressure or anti-siphon valves, and pressure relief valves. They all feature a completely adjustable pressure range of 0 - 150 PSIG and a built-in air release to reduce priming difficulties. The valves are available in sizes from 1/4" through 2", eight materials of construction and offer a three year warranty. Socket weld, flanged or special threaded connections are available. Higher temperature and pressure valves are available on request.

FLOW DETAILS

Flow capacity through TOP VALVE back pressure / anti-siphon and pressure relief valves under continuous flow conditions at 345 kPa with ambient temperature water is outlined in the following table.

Size of valve	1/4"	1/4" x 1/2"	1/2"	3/4"	1"	1 1/2"	2"
Flow Rate L/H	455	565	1135	1360	2500	5675	9085

Note:

- Flow capacity increases with pressure – if pressure is doubled, the flow rate will approximately double.
- Pulsation flows (from reciprocating pumps) create flow peaks. To calculate the flow your application requires, divide the given flow rate by three. For example, a 1" back pressure valve used for a reciprocating pump will have a maximum flow rate of approximately 830 L/H at 345 kPa.
- The 1/4" x 1/2" Valve has a 1/4" orifice x 1/2" process connections.

VALVE SELECTION

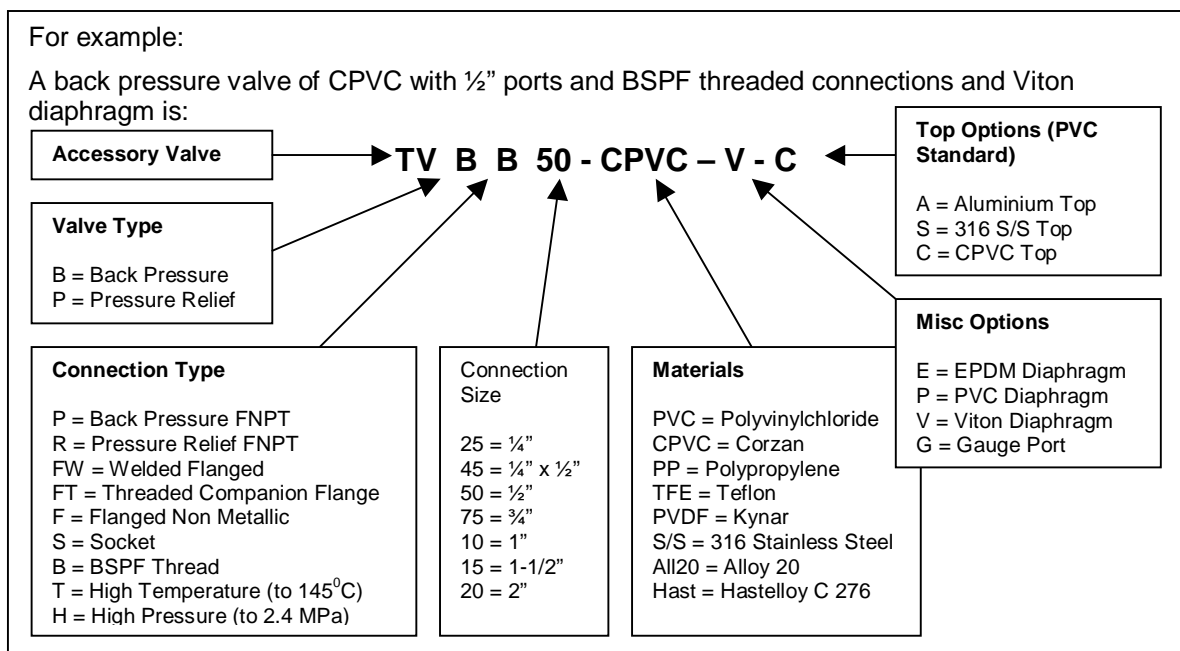

H2O Rx
PO Box 748
Lane Cove NSW 1595

Phone: 0409 784 236
Fax: (02) 9436 0491
Web: www.h2orx.com
Email: info@h2orx.com
Literature Request: TV